

# Nakamichi **LX-5**

Discrete Head Cassette Deck

Owner's Manual



## CAUTION

TO REDUCE THE RISK OF ELECTRIC SHOCK, DO NOT REMOVE COVER (OR BACK). NO USER-SERVICEABLE PARTS INSIDE. REFER SERVICING TO QUALIFIED SERVICE PERSONNEL.

 The lightning flash with arrowhead symbol, within an equilateral triangle, is intended to alert the user of the presence of uninsulated "dangerous voltage" within the product's enclosure; that may be of sufficient magnitude to constitute a risk of electric shock to persons.

 The exclamation point within an equilateral triangle is intended to alert the user of the presence of important operating and maintenance (servicing) instructions, in the literature accompanying the appliance.

## WARNING

TO PREVENT FIRE OR SHOCK HAZARD, DO NOT EXPOSE THIS APPLIANCE TO RAIN OR MOISTURE.

Please record the Model Number and Serial Number in the space provided below and retain these numbers.

Model Number and Serial Number are located on the rear panel of the unit.

Model Number: Nakamichi LX-5

Serial Number: \_\_\_\_\_

### CONTENTS

Safety Instructions.....	1
On Cassette Tapes .....	2
Precautions.....	2
Controls and Features.....	3
Connections .....	6
Special Features.....	7
Playback .....	9
Matching the Cassette Deck to Various Cassette Tapes.....	10
Recording .....	12
Tips on Setting Record Levels.....	13
Dolby Noise Reduction System .....	14
Maintenance.....	15
Troubleshooting.....	16
Specifications/Optional Accessories .....	17

**Congratulations!**

**You have chosen an excellent cassette deck.**

**The Nakamichi LX-5 was designed to fulfill the highest aim of a tape deck—perfectly faithful sound reproduction. This aim is achieved by giving great attention to basic performance characteristics, while keeping operation of the deck easy and simple. A micro-processor is employed for tape transport control, which ensures smooth and error-free operation.**

**Please take the time to read this manual in its entirety to fully acquaint yourself with the various features of this cassette deck.**

**Thank you.**

**Nakamichi Corporation.**

# Safety Instructions

The following safety instructions have been included in compliance with safety standard regulations. Please read them carefully.

1. **Read Instructions** — All the safety and operating instructions should be read before the appliance is operated.
2. **Retain instructions** — The safety and operating instructions should be retained for future reference.
3. **Heed Warnings** — All warnings on the appliance and in the operating instructions should be adhered.
4. **Follow Instructions** — All operating and use instructions should be followed.
5. **Water and Moisture** — The appliance should not be used near water — for example, near a bathtub, washbowl, kitchen sink, laundry tub, in a wet basement, or near a swimming pool, etc.
6. **Carts and Stands** — The appliance should be used only with a cart or stand that is recommended by the manufacturer.
7. **Wall or Ceiling Mounting** — The appliance should be mounted to a wall or ceiling only as recommended by the manufacturer.
8. **Ventilation** — The appliance should be situated so that its location or position does not interfere with its proper ventilation. For example, the appliance should not be situated on a bed, sofa, rug or similar surface that may block the ventilation openings; or placed in a built-in installation, such as a bookcase or cabinet that may impede the flow of air through the ventilation openings.
9. **Heat** — The appliance should be situated away from heat sources such as radiators, heat registers, stoves, or other appliances (including amplifiers) which produce heat.
10. **Power Sources** — The appliance should be connected to a power supply only of the type described in the operating instructions or as marked on the appliance.
11. **Grounding or Polarization** — Precautions should be taken so that the grounding or polarization means of an appliance is not defeated.
12. **Power-Cord Protection** — Power-supply cords should be routed so that they are not likely to be walked on or pinched by items placed upon or against them, paying particular attention to cords at plugs, convenience receptacles, and the point where they exit from the appliance.
13. **Cleaning** — The appliance should be cleaned only as recommended by the manufacturer.
14. **Nonuse Periods** — The power cord of the appliance should be unplugged from the outlet when left unused for a long period of time.
15. **Object and Liquid Entry** — Care should be taken so that objects do not fall and liquids are not spilled into the enclosure through openings.
16. **Damage Requiring Service** — The appliance should be serviced by qualified service personnel when:
  - A. The power-supply cord or the plug has been damaged; or,
  - B. Objects have fallen, or liquid has been spilled into the appliance; or,
  - C. The appliance has been exposed to rain; or,
  - D. The appliance does not appear to operate normally or exhibits a marked change in performance; or,
  - E. The appliance has been dropped, or the enclosure damaged.
17. **Servicing** — The user should not attempt to service the appliance beyond that described in the operating instruction. All other servicing should be referred to qualified service personnel.

## Precautions

1. C-120 cassettes (playing time one hour per side) contain extremely thin tape which breaks or snarls easily, is sometimes subject to stretching and also is of low sensitivity. Therefore, C-120 cassettes are not recommended for high-fidelity recording.
2. Do not pull out the tape from the cassette housing.
3. Be careful not to turn the cassette reels with the fingers, causing tape slackening.
4. Store cassette tapes away from heat, high humidity, dust, and magnetic fields such as caused by speakers, TV sets etc.

## Cassette Tabs

You can protect valuable recordings from accidental erasure and re-recording by completely removing the appropriate tab on the top edge of the cassette. The tab for each side is located on the top left-hand corner as you face the side. Use a small screwdriver, and push the tab down to break it off. Do not leave the broken tab in the recess. If you wish at a later date to record over a side for which the tab has been removed, cover the tab opening with a piece of adhesive tape.

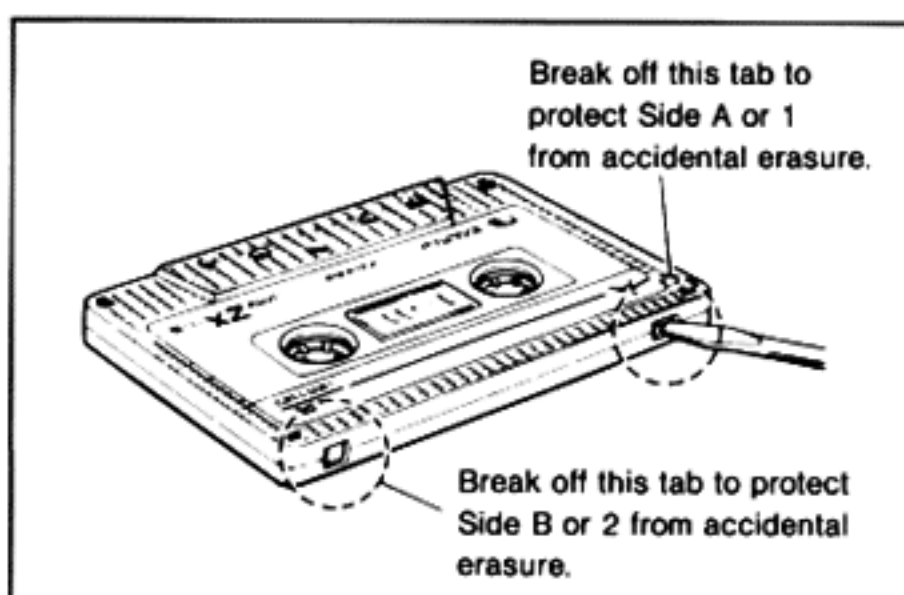

## Insertion and Removal

### (1) Insertion of a Cassette

1. Push the eject button to open the cassette holder.
2. Insert the cassette into the cassette holder from the top. Make sure that the exposed tape is facing down and the label of the desired side is facing you.
3. Gently push the cassette holder back into the panel.

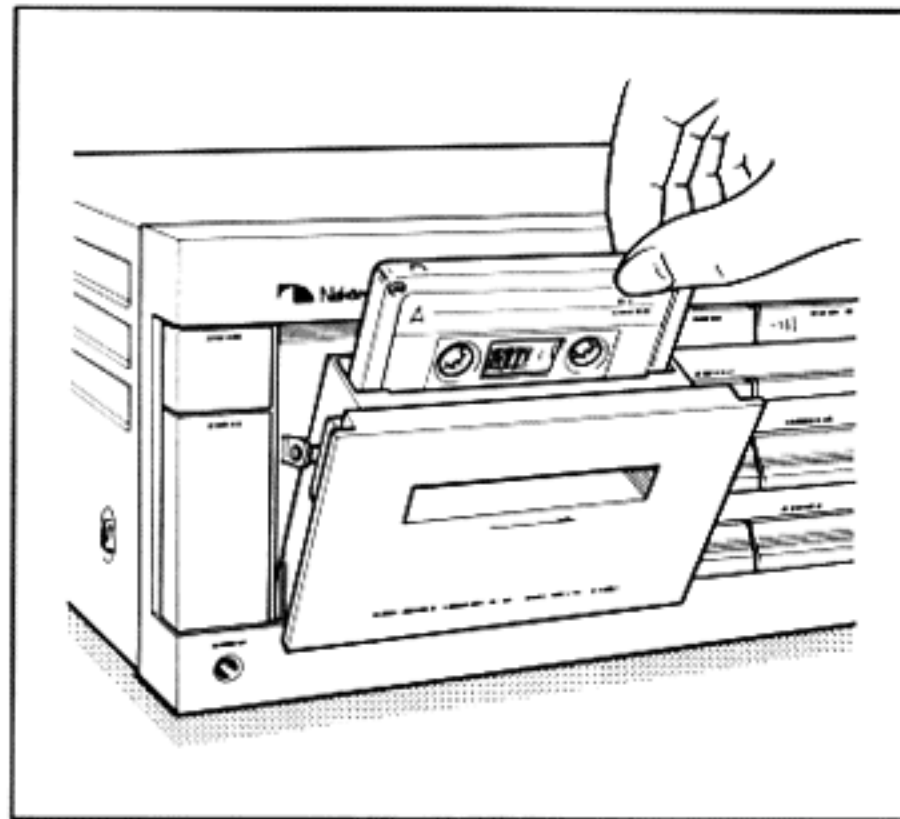

### (2) Removal of a Cassette

1. Press the stop button
2. Push the eject button to open the cassette holder.
3. Remove the cassette.

1. Make sure that the timer switch (16) is set to "Off" when the self-start feature is not desired.
2. This deck incorporates a special circuit designed to take up any loose tape inside the cassette. When a tape is inserted, the take-up spindle (right-hand spindle) will make a few rotations. The take-up spindle will also rotate and the tape counter will advance by a few digits if: a cassette containing loose tape is inserted, or the cassette holder is closed without a cassette, or the power to the deck is switched on. This behavior is normal and not a fault with the deck.
3. This deck incorporates a muting circuit to prevent the generation of spurious noise when switching on the power. While the muting circuit is active, the light above the stop button (8) flashes and the tape transport buttons ("Play", "F.Fwd", "Rew" and "Pause") are inoperative. When the timer function for recording or playback is used, the respective mode is entered after the muting interval (when the flashing of the stop button light has stopped).



**(1) Power Switch**

Pressing this button activates the deck. Pressing it once more switches the power off. When the power is switched on, the cassette holder illumination is lit and the tape counter (26) is reset.

**(2) Eject Button**

By depressing this button, the cassette holder is opened for insertion and removal of a cassette.

**(3) Headphone Jack**

Accepts standard stereophone plug. (→p. 6)

**(4) Cassette Holder**

See-thru cover provides unobstructed view of the cassette. The cover can be easily removed for routine cleaning of heads, capstans and pinchrollers etc. (→p. 15)

**(5) Rewind Button**

For rapid tape-winding in the reverse direction. During operation, the indicator on the top right of the button lights up.

**(6) Pause Button**

Used for noise-free, short-term interruption of the tape transport in recording or playback. During operation, the indicator on the top right of the button lights up.

**(7) Play Button**

Starts forward tape motion for recording or playback. During operation, the indicator on the top right of the button lights up.

**(8) Stop Button**

Brings all tape motion to a full stop from any mode. During operation, the indicator on the top right of the button lights up.

**(9) Fast-Forward Button.**

For rapid tape winding in the forward direction. During operation, the indicator on the top right of the button lights up.

**(10) Record Button**

Used for recording and also for the auto play feature (→p. 7). During recording, the indicator on the top right of the button lights up.

**(11) Tape Selector Switch**

Used to select the EX, SX or ZX position. For Nakamichi EX and EX II tapes or other low-noise/high output ferric oxide tapes, set the switch to the "EX" position. For Nakamichi SX tape or other chrome-equivalent tapes, use

the "SX" position. For Nakamichi ZX or other metal tapes, use the "ZX" position. (→p. 10)

**(12) Bias Tune Control**

Used for fine tuning of the bias current. (→p. 11)

**(13) Eq Switch**

Used to select either 70 or 120 microsecond equalization. (→p. 10)

**(14) Tape Start Memory Switch**

When this switch is set to "On", the tape is automatically stopped at the tape counter indication "0000" in rewind or fast-forward (memory feature). This deck also incorporates an auto play feature. It is activated by means of the record button and puts the deck into the playback mode at "0000". (→p. 7)

**(15) Dolby NR Switch**

Used to select Dolby B-Type noise reduction for a 10-dB improvement in high-frequency S/N ratio, or Dolby C-Type noise reduction for a 20-dB improvement. When a Dolby system is used, the respective indicator (22) lights up. (→p. 14)

**(16) Timer Switch**

Permits unattended recording or pre-programmed playback in conjunction with an external audio timer (→p. 8)

**(17) Input Level Controls (L,R)**

Used to adjust the input (record) level to the deck and the left/right channel balance. (→p. 12). Fade-in or fade-out can be performed with the master fader control (25). (→p. 7)

**(18) MPX Filter Switch**

When this switch is set to "On", a filter cuts off the 19-kHz multiplex carrier signal used in FM stereo broadcasts. Remains of this carrier might otherwise interfere with correct operation of the Dolby system. This switch should be set to "Off" when recording anything else than FM broadcasts.

**(19) Output Level Control**

Controls the output level of the deck as well as the headphones listening level for both channels simultaneously.

**(20) Peak Level Meters**

Provide exact indication of peak levels in the wide range of -40 dB to +10 dB. (→p. 13)

**Hinged Panel**

The various control switches of this cassette deck are located beneath a hinged panel. The panel is opened by a slight push on the upper right corner. For protection, the hinged panel is designed to become unhinged if strong force is applied while it is open. In such a case, be sure to correctly re-attach the panel before closing it.

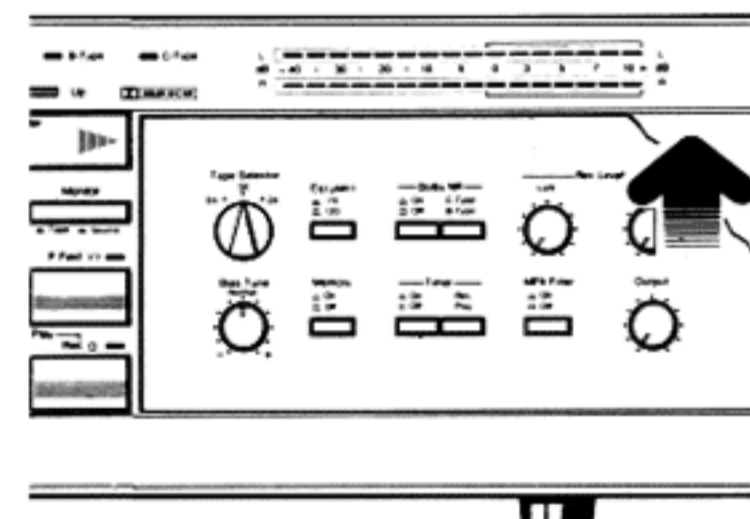
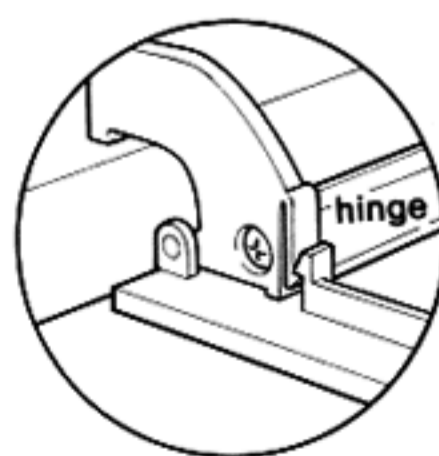

Lock back into place by pressing hinged panel and hinge together.

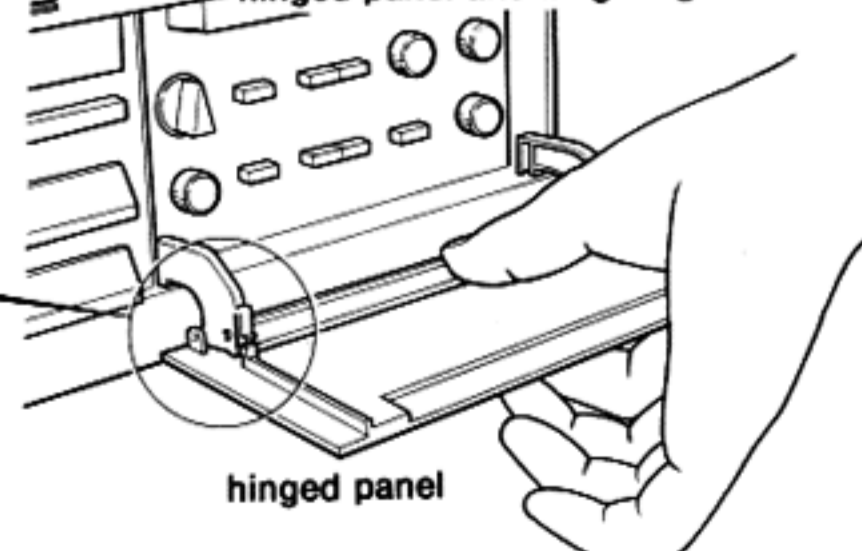

**(21) Monitor Switch**

For playback of a tape and for off-the-tape monitoring during recording, set this switch to "Tape". For record level setting etc., set this switch to "Source".

**(22) Dolby NR Indicators**

When a Dolby NR system is used, the respective indicator lights up.

**(23) Rec Mute Indicator**

Lights up during rec mute operation.

**(24) Master Fader Indicators**

Display the condition of the master fader control.

**(25) Master Fader Control**

By means of this control, fade-in or fade-out during recording can be performed easily at the touch of a button. There is also a choice between two fading speeds. The master fader indicators (24) display the condition of the master fader control. (→p. 7)

**(26) Tape Counter**

Digital LED indicators count from "0000" to "9999" in the record, playback and fast-forward modes ("plus count"), and to "-999" in the rewind mode ("minus count").

**(27) Rec Mute Button**

By depressing this button during recording, the input signal can be temporarily cut off. During operation, the rec mute indicator (23) lights up. (→p. 7)

**(28) Counter Reset Button**

Pressing this button returns the tape counter indication to "0000".

**(29) Input Jacks (Left and Right Channel)****(30) Output Jacks (Left and Right Channel)****(31) Remote Control Jack**

Accepts the respective plug of an optional remote control unit for operation of the tape transport.

**(32) Power Cord****(33) Voltage Selector**

AC voltage is factory-set for the country in which you purchased your LX-5. The voltage selector permits re-setting of mains voltage in case the deck is to be used in a different country.

**Note:**

Safety regulations in certain countries prohibit inclusion of a voltage selector. This feature, therefore, may be absent from your deck.



## Connection of Amplifier and Remote Control

After checking the instructions for your amplifier or receiver, use the shielded cables with RCA plugs (provided with the deck) to securely connect this deck's input jacks (29) with the "Rec Out" terminals on the amplifier and this deck's output jacks (30) to the "Tape Play" terminals on the amplifier. Be careful not to mix up left and right channels. While making connections, the power to the deck and to the amplifier should be switched off.

## Remote Control

The optional remote control unit RM-200 permits operation of the deck's tape transport functions (excluding the rec mute function) from any convenient location.

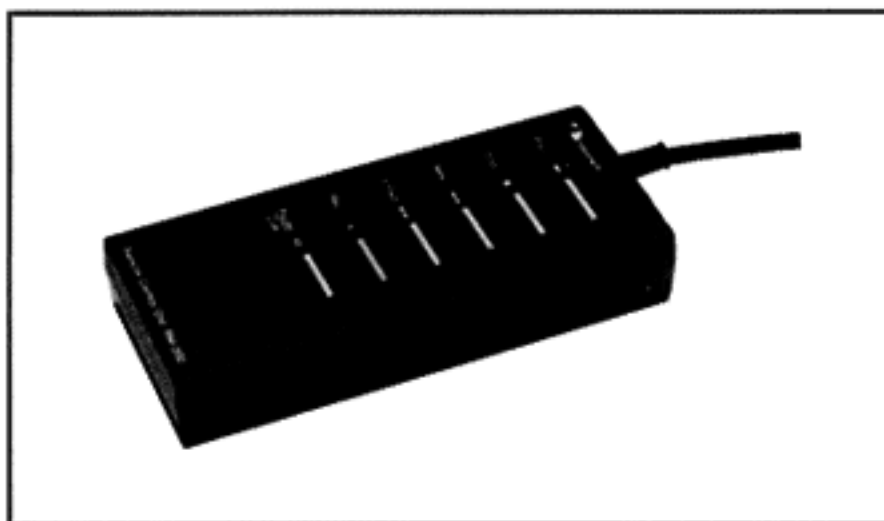

## Headphones

Standard stereo headphones may be connected to the jack on the front panel of the deck. Low-impedance headphones of 8 to 16 ohms are recommended.

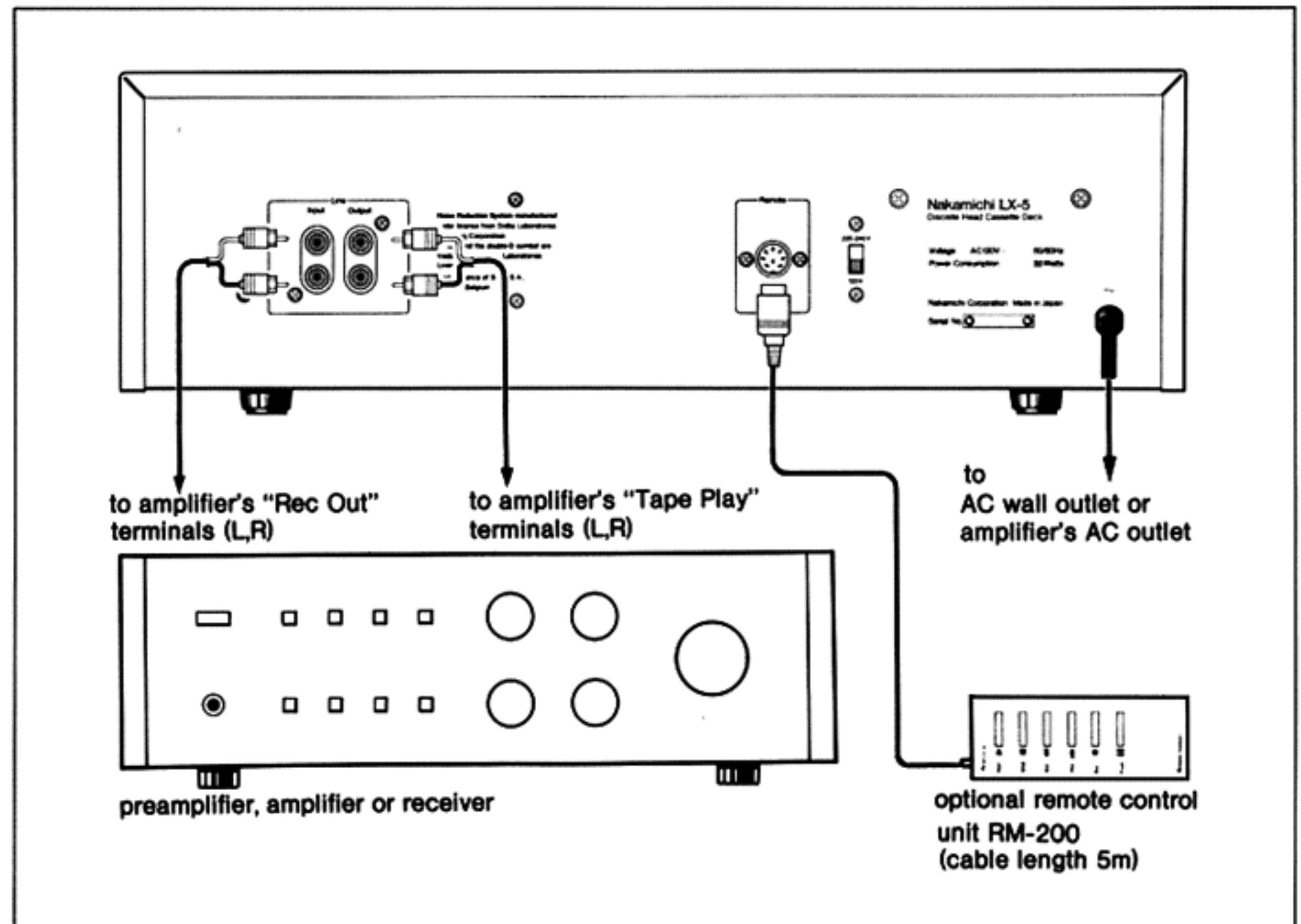
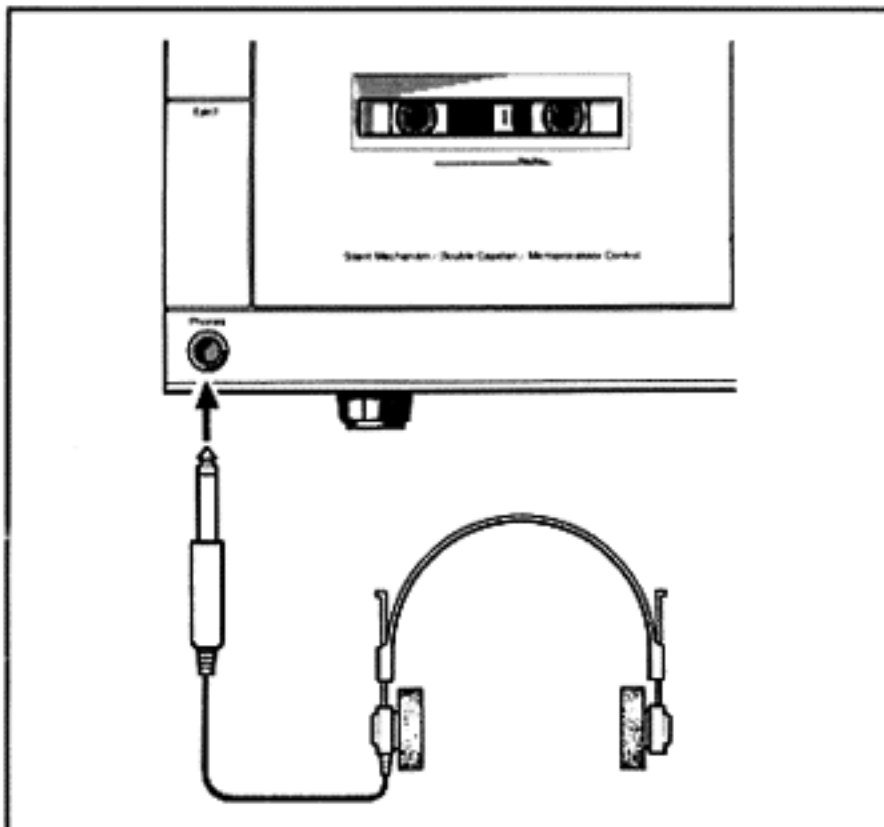

## Connection of Microphone Amplifier

As the LX-5 possesses only line input facilities, it is not possible to directly connect microphones to the deck. When microphones are to be used, a separate microphone amplifier such as the optional MX-100 Microphone Mixer from Nakamichi's BlackBox series (PS-100 Power Supply required) is necessary.

### MX-100 Microphone Mixer

For microphone recordings, we recommend the use of the MX-100 Microphone Mixer. This unit provides three inputs (left, right and center "blend") which can be mixed freely. For detailed instructions, please refer to the instruction booklet supplied with the MX-100.

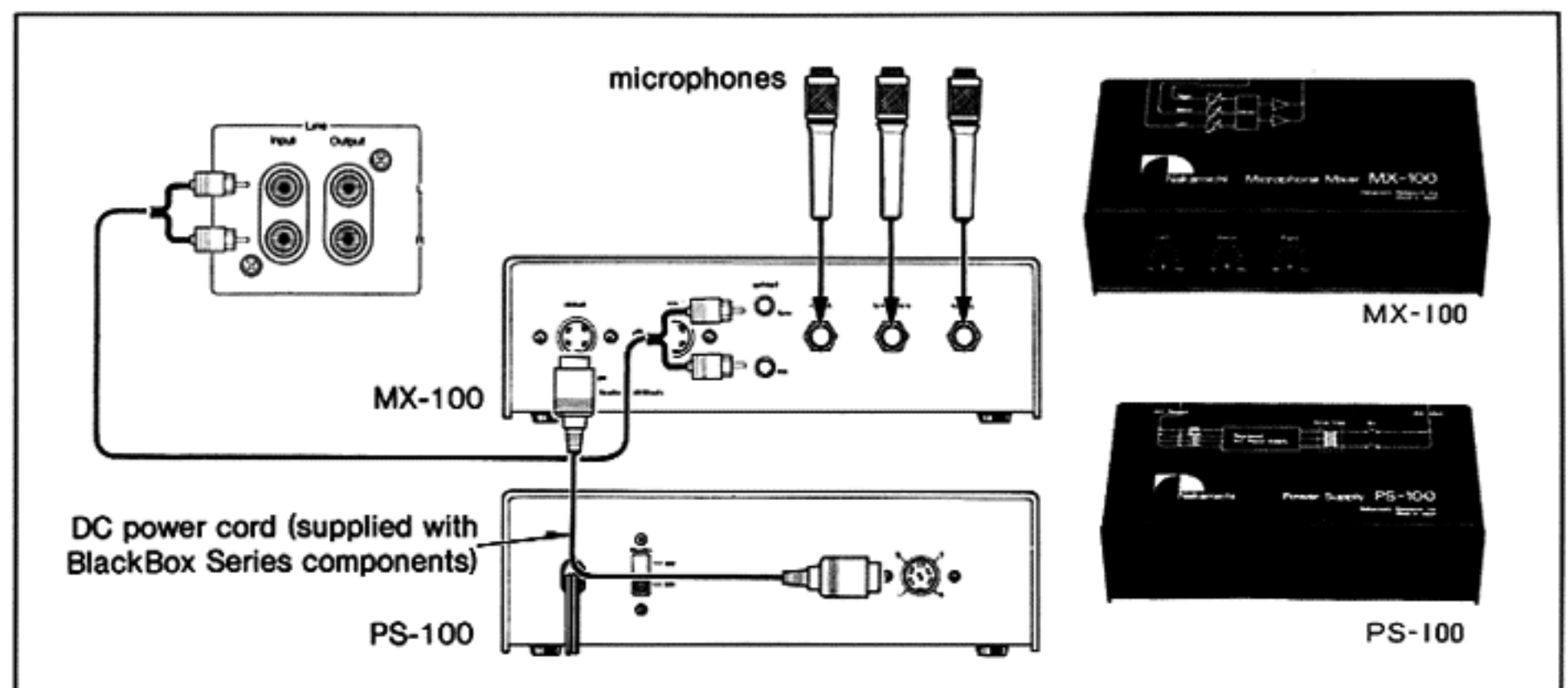

# Special Features

## 1. Master Fader Control

This feature permits smooth and easy fades during recording simply by pressing a button. Fade-in is performed by depressing the "Up ▷" side of the master fader control (25), and fade-out is performed by depressing the "Down ◁" side.

You can choose between two fading speeds: Depressing the button strongly (two clicking sounds of the switch) and keeping it depressed causes the fading process to be performed in about 2 seconds. Depressing the button lightly (one clicking sound of the switch) or releasing the button after one push causes the fading process to be performed in about 6 seconds.

The respective fading mode is indicated by the relative brightness of the indicators (24). In ordinary music recording, slow-speed fading may be more desirable, while high-speed fading can be used effectively for example to eliminate noise when the cartridge is lowered onto a record, etc.

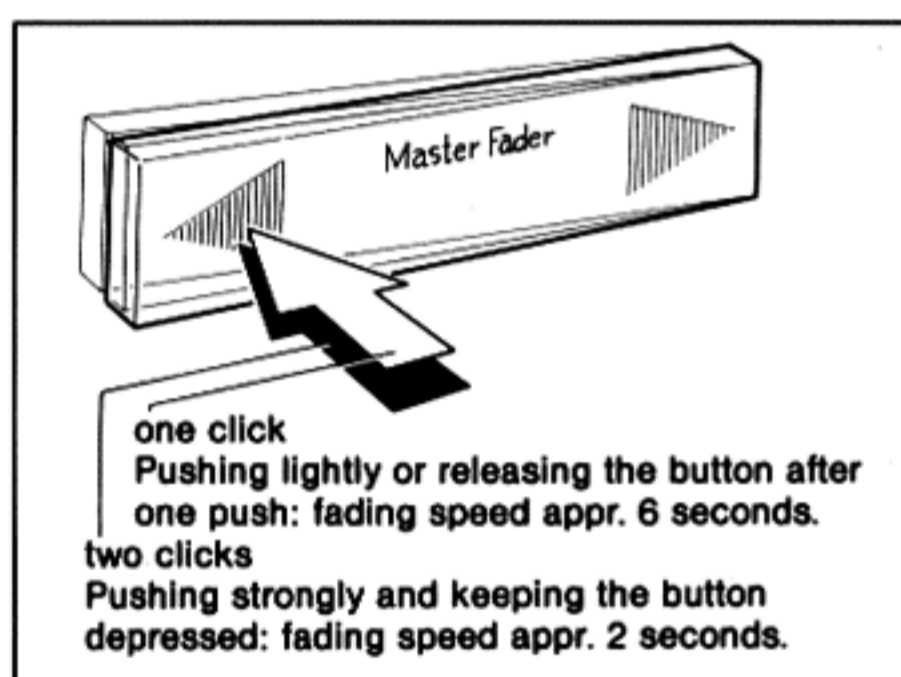

### Note:

- The operation of the master fader control can be changed from "Up" to "Down" or from "Down" to "Up", but it can not be stopped midway.
- The master fader control is operative only in the record and record-standby modes. In other modes, the setting is automatically "Up".

## 2. Auto Play Feature

This feature is operated by means of the rewind button (5) or fast-forward button (9) and the record button (10). "Auto Play" means that the tape is stopped from rewind or fast-forward at the counter indication "0000" and the deck automatically starts playback from this point.

### -Operation-

- (1) Press the counter reset button (28) at the beginning of a recording or playback to return the counter indication to "0000".
- (2) After recording or playback is completed, press the rewind button (5), lighting up the indicator above the button, and then—while keeping the rewind button depressed—press the record button (10). The tape will now be rewound to the "0000" indication and playback will automatically start from there. The auto play feature can also be activated while the deck is already in the rewind mode: just press the rewind button once again and then press the record button.

The above description is an example for the rewind mode, but the auto play feature can be operated in the same way in the fast-forward mode also.

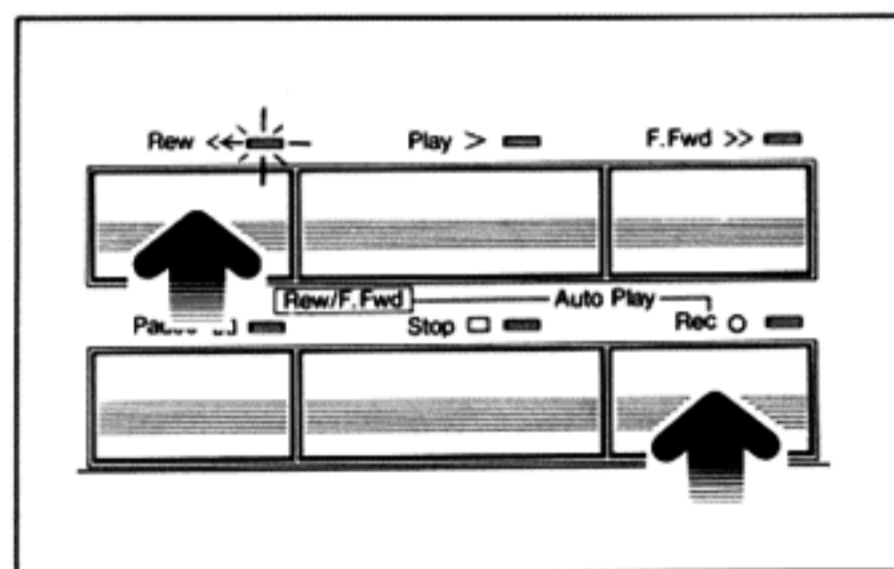

### Note:

- Depressing the record button to activate the auto play feature does not light the record button indicator.
- When auto play is used, the deck starts playback at "0000", also when the tape start memory switch (14) is set to "On".

## 3. Rec Mute

By pressing the rec mute button (27) during recording, the input signal is cut off for as long as the button is being kept depressed. This can be used to insert silent spaces on a tape or suppress unwanted portions of a recording source. The rec mute indicator (23) lights up while the signal is cut off. When the monitor switch (21) is set to "Source", the line output and the headphone jack are not muted, so that it is possible to continuously monitor the input signal.

The rec mute indicator (23) is set to display the condition when the recording signal current is cut off. Therefore the indicator lights up not only during rec mute operation, but also in the record-standby mode. When entering the record mode from the stop mode, the rec mute indicator lights up for an instant, because the muting is activated until the heads touch the tape.

## 4. Punch-In Recording

Going from the playback mode directly into the record mode without pressing the stop button is called punch-in recording. This can be used to immediately start a recording from playback or to later insert another recording source on silent passages left in a previous recording, etc. Also, with this deck the record-standby mode can be entered directly from the pause mode without using the stop button.

### -Operation-

In the playback mode, while depressing the play button (7), press the record button (10). In addition to the play button indicator, the record button indicator also lights up and recording starts without the tape motion being stopped.

To enter the record-standby mode from the pause mode, press the record button (10) while depressing the pause button (6). The record button indicator flashes for about 2 seconds and then lights up continuously, indicating record-standby.

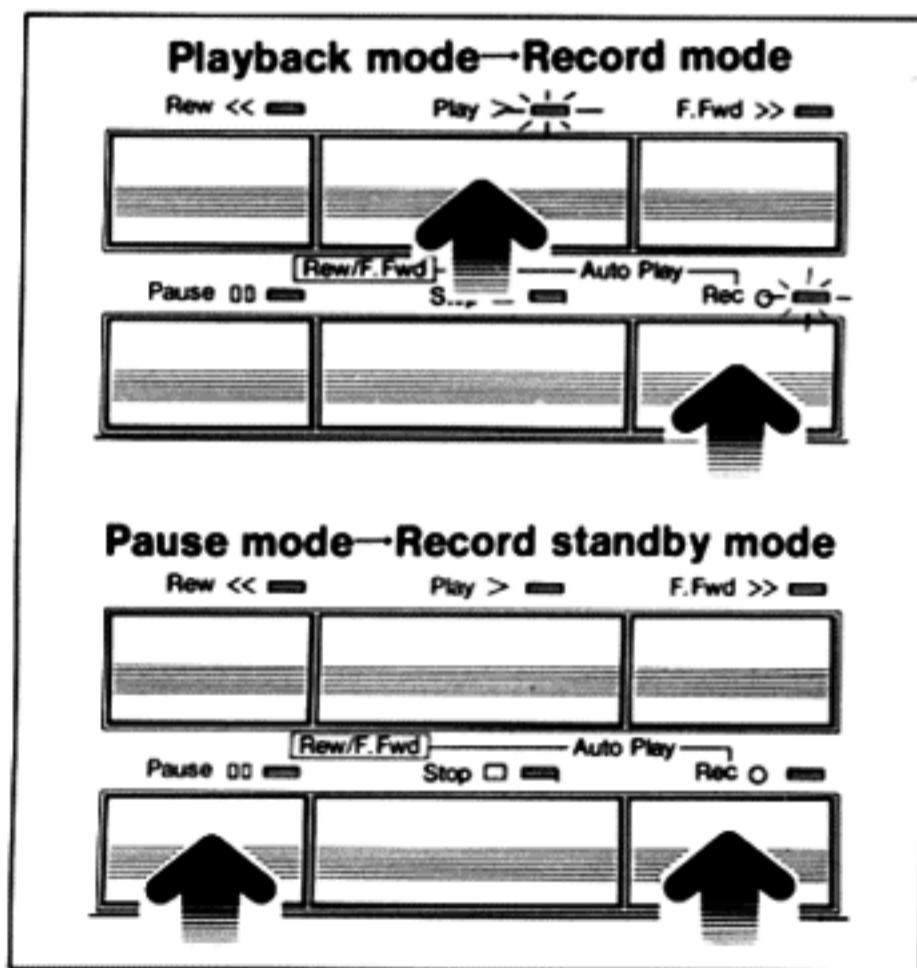

### Note:

- If the tabs on the rear of the cassette are removed, it is not possible to enter the record mode.
- For punch-in recording, always press the play button (7) or the pause button (6) before you press the record button (10). If the record button is pressed first, the operation cannot be performed.

## 5. MPX Filter

In the transmission of FM stereo broadcasts, a 19 kHz multiplex carrier signal is used. When recording from FM stereo broadcasts while using the Dolby noise reduction system, possible residues of this 19 kHz signal can cause malfunction of the noise reduction circuitry. To prevent this, the MPX filter cuts off any remaining carrier signal. Therefore, when recording from FM stereo broadcasts, set the MPX filter switch (18) to "On". The switch should be "Off" when recording anything else than FM stereo broadcasts.

## 6. Timer Recording or Playback

This deck incorporates a self-start feature which enables you to make unattended recordings or start playback at a pre-selected time with the use of a timer.

### -Operation-

- (1) Make connections as shown in the chart.

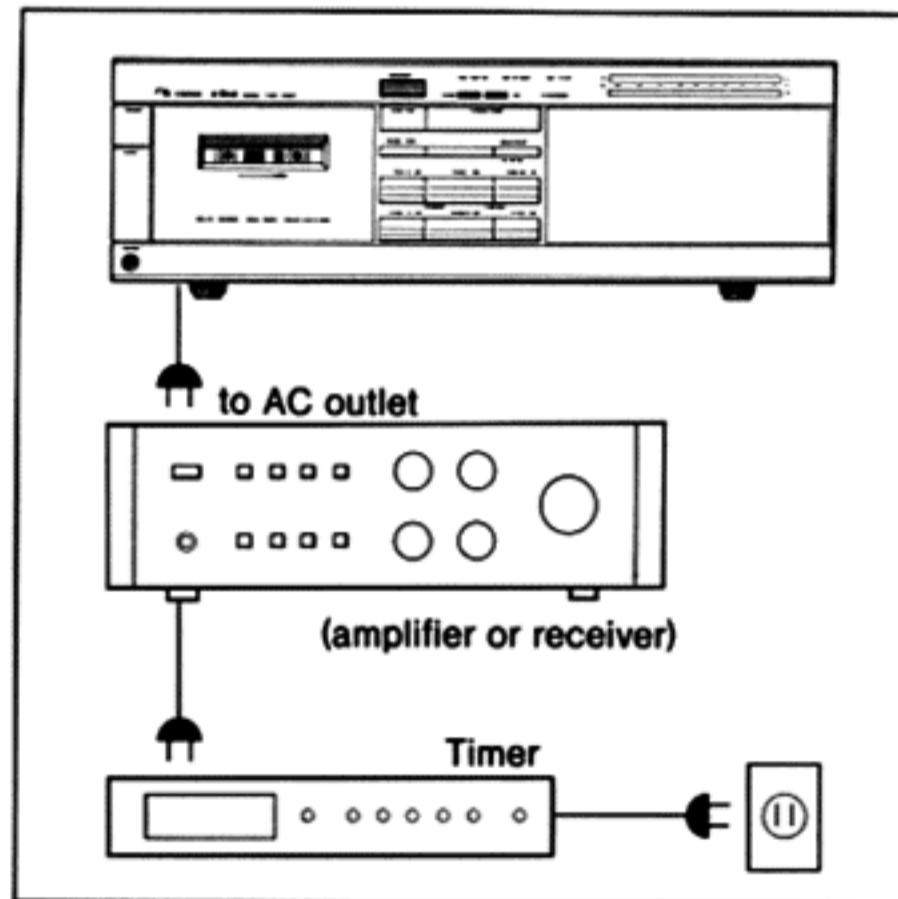

- (2) Insert the tape for recording or playback and turn on the power to all components.
- (3) For timer recording, set the recording level to suit the expected signal. For timer playback, set the output control to the desired level. Check if all components are set up properly.

- (4) Set the On/Off button (left button) of the timer switch (16) to "On" and the Rec/Play button (right button) of the timer switch to the desired position ("Rec" for unattended recording, "Play" for timer playback).

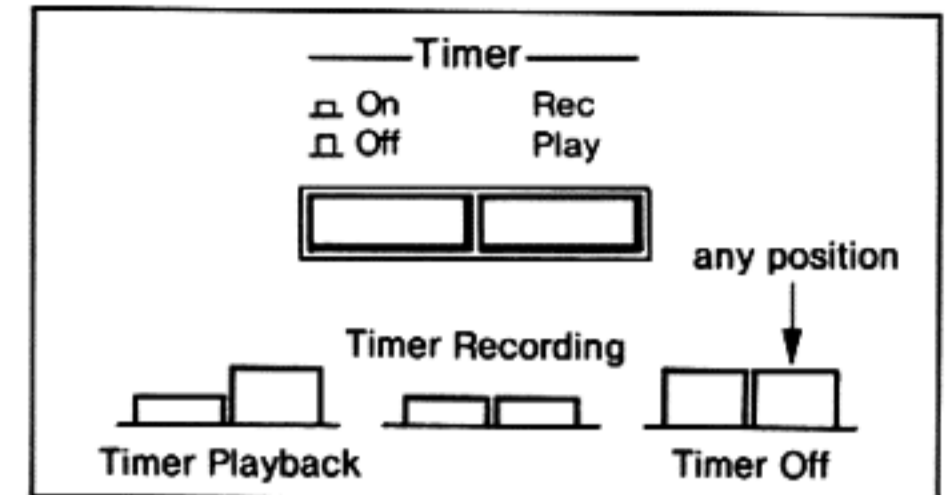

- (5) Adjust the timer to the desired starting time.
- (6) At the pre-selected time, the timer will supply power to the components and the LX-5 will start recording or playing.

### Note:

- When the timer recording or playback feature is not desired, be sure to set the On/Off button of the timer switch to "Off".

## 7. Head Configuration

In order to obtain the best parameters for each function and to extract the utmost from every tape, this deck possesses completely separate erase, recording and playback heads. The monitor switch permits instant off-the-tape monitoring during recording.

# Playback

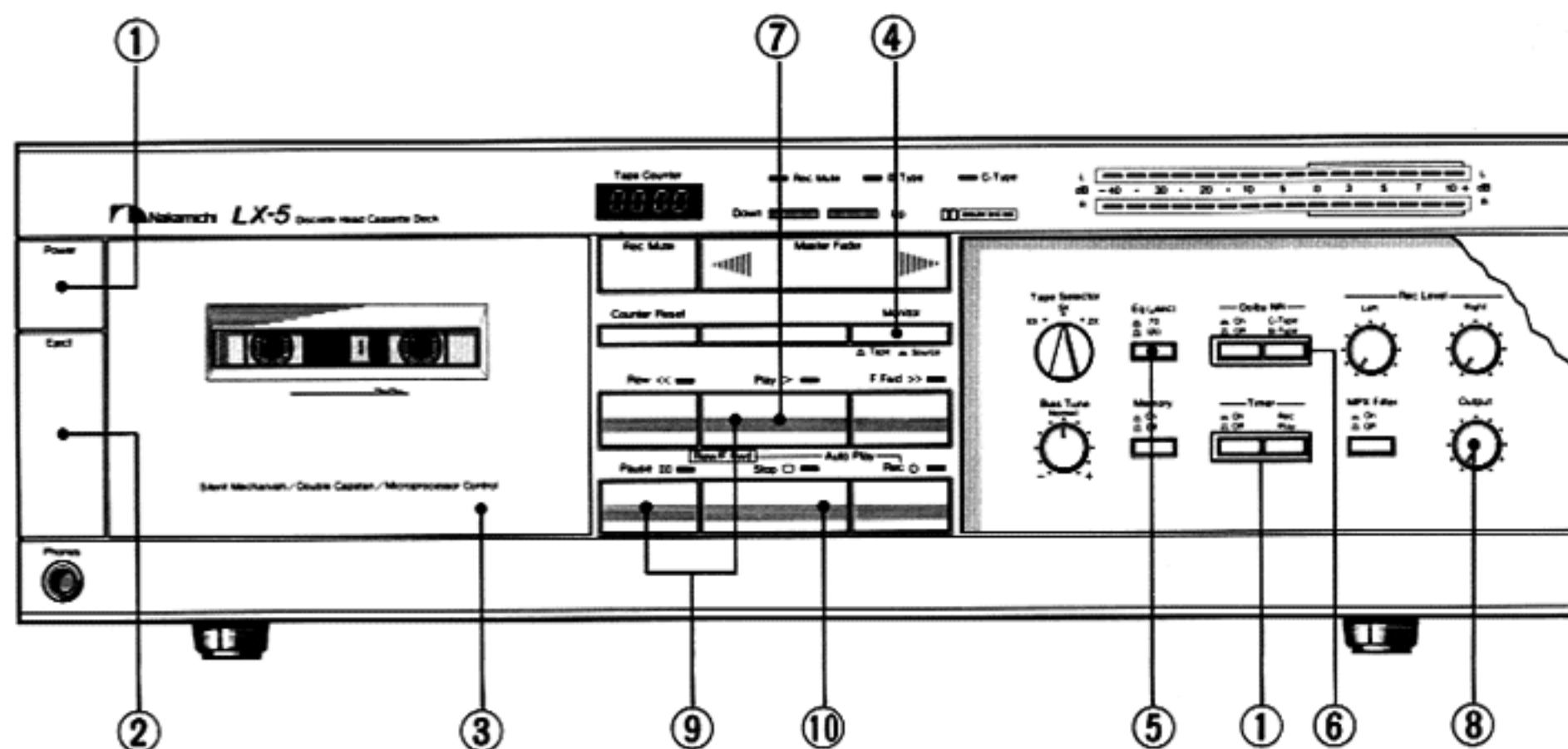

- ① Confirm that the On/Off button (left button) of the timer switch (16) is set to "Off". Turn on the power to the deck by depressing the power switch (1).
- ② Press the eject button (2) to open the cassette holder (4).
- ③ Insert the cassette tape into the holder with the exposed tape facing down and the desired side facing outwards. Push the cassette holder back until it locks into the panel.
- ④ Set the monitor switch (21) to "Tape".
- ⑤ Set the Eq switch (13) to 120  $\mu$ s or 70  $\mu$ s, according to the tape used. (→p. 10)
- ⑥ When playing back a tape which was recorded with Dolby B-Type noise reduction, set the On/Off button (left button) of the Dolby NR switch (15) to "On" and the C-Type/B-Type button (right button) to "B-Type".  
When playing back a tape which was recorded with Dolby C-Type noise reduction, set the On/Off button (left button) of the Dolby NR switch (15) to "On" and the C-Type/B-Type button (right button) to "C-Type". The respective indicator of the Dolby NR indicators (22) lights up. When playing back a tape which was recorded without Dolby noise reduction, set the On/Off button to "Off".

Dolby NR		
	On	C-Type
	Off	B-Type
Playback with B-Type NR	<input checked="" type="checkbox"/>	<input checked="" type="checkbox"/>
Playback with C-Type NR	<input checked="" type="checkbox"/>	<input checked="" type="checkbox"/>
Playback without Dolby NR	<input checked="" type="checkbox"/>	any position

- Note:**
- Ordinary Dolby-encoded tapes, which were not recorded with Dolby C-Type noise reduction, are to be played back at the "B-Type" position.
- ⑦ Press the play button (7).
  - ⑧ Adjust the output level control (19) to the desired level.
  - ⑨ For short-term interruption of playback, press the pause button (6). To resume playback, press the play button (7) again.
  - ⑩ To stop the tape altogether, press the stop button (8).
  - ⑪ When the tape end is reached, the tape transport is shut off automatically.

- Note:**
- The transport of this deck permits going from any transport mode into any other (i.e. from play to rewind, from rewind to fast-forward, etc.) without having to use the stop button.
  - While the tape is in motion or in the pause mode, the eject button is inoperative and the cassette holder does not open even if the button is depressed. While the cassette holder is open, logic circuitry prevents operation of all transport modes.
  - During playback, the deck's peak level meters display the level recorded on the tape. Readings are not affected by turning the output level control.

# Matching the Cassette Deck to Various Cassette Tapes

There are many brands of cassette tapes, which can be generally classified into three types: normal tapes (ferric-oxide formulations), chrome-equivalent tapes, and metal tapes. When recording such tapes with this deck, the tape selector switch (11) and the Eq switch (13) must be set according to the chart below.

In order to fully realize this deck's potential, you should use tapes from the list below, whenever possible.

## Tape Selector Switch

This switch serves to select the appropriate bias amount and record equalization for different tape types. If bias current is too low, high-frequency response rises but distortion also increases. If it is too high, high-frequency response as well as distortion decline. This deck's tape selector switch provides three positions: EX (normal tapes) SX (chrome-equivalent tapes) and ZX (metal tapes). According to the tape used, the correct position must be selected. The position of this switch is relevant only in recording and has no effect during playback.

## Eq Switch

In order to match the deck to the characteristics of the tape, besides bias it is necessary to select the correct equalization for recording and playback. This deck provides two Eq switch positions: "70  $\mu$ s" and "120  $\mu$ s". Metal tapes (ZX) and chrome-equivalent tapes (SX) are to be used with "70  $\mu$ s" and normal tapes (EX) with "120  $\mu$ s". This switch must be set to the correct position in recording as well as in playback.

## Tape Selector Switch and Eq Switch Settings (Recommended Tapes)

### ■ EX/120 $\mu$ s Position

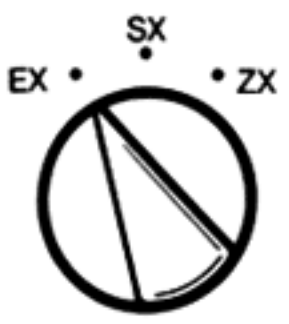
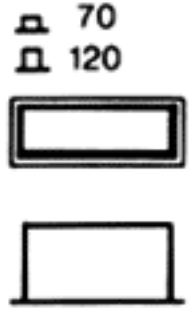
Tape Selector Switch	Eq Switch	Brand Name
		<b>Nakamichi</b> EX, EX II <b>TDK</b> AD, AD-X <b>Maxell</b> UD, UD-XL I, XL I-S <b>Fuji</b> FR-I

### ■ SX/70 $\mu$ s Position

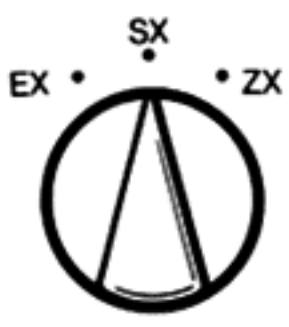
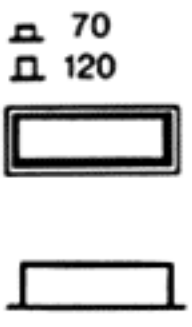
Tape Selector Switch	Eq Switch	Brand Name
		<b>Nakamichi</b> SX, SX II <b>TDK</b> SA, SA-X <b>Maxell</b> UD-XL II, XL II-S <b>Fuji</b> FR-II

### ■ ZX/70 $\mu$ s Position

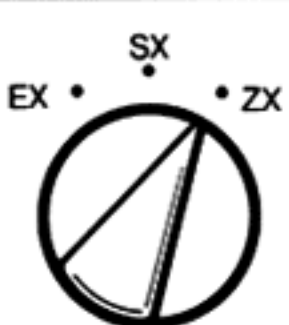
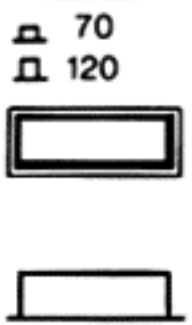
Tape Selector Switch	Eq Switch	Brand Name
		<b>Nakamichi</b> ZX <b>TDK</b> MA, MA-R <b>Maxell</b> MX <b>Fuji</b> FR-Metal

**Note:** —This deck is not suited for use with ferrichrome (FeCr) tapes.

## Bias Tune Control

This deck provides a bias tune control (12), which permits fine adjustment of the bias current after the standard values have been set by means of the tape selector switch (11). When using tapes recommended by this manufacturer (see list in preceding paragraph), the bias tune control should be left in the center click-stop position.

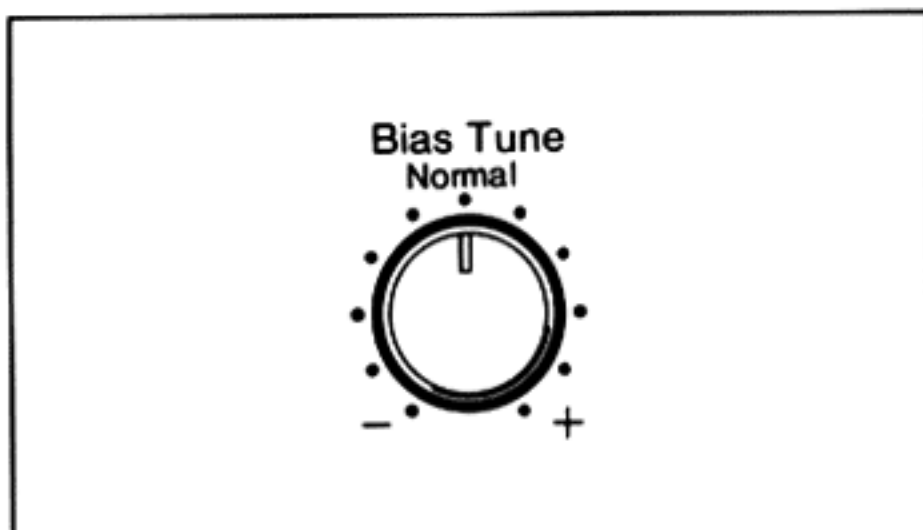

When using other tapes, the bias tune control should be adjusted as follows.

The discrete 3-head configuration permits bias adjustment while instantly monitoring the recorded signal.

1. Compare the source signal ("Source") with the recorded signal ("Tape").

If the recorded signal sounds brighter (has more highs) than the original source, turn the bias tune control to the right (clockwise).

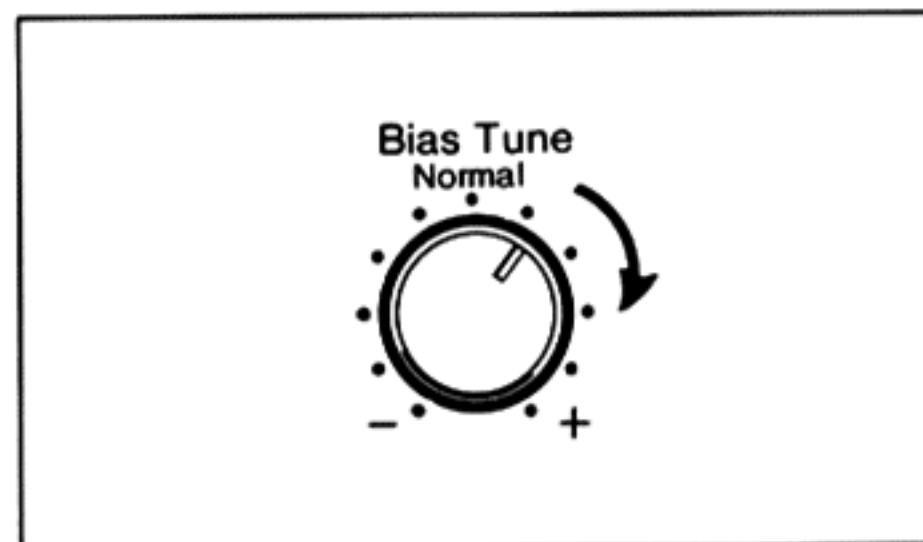

2. If the recorded signal sounds duller (has less highs) than the original source, turn the bias tune control to the left (counterclockwise).

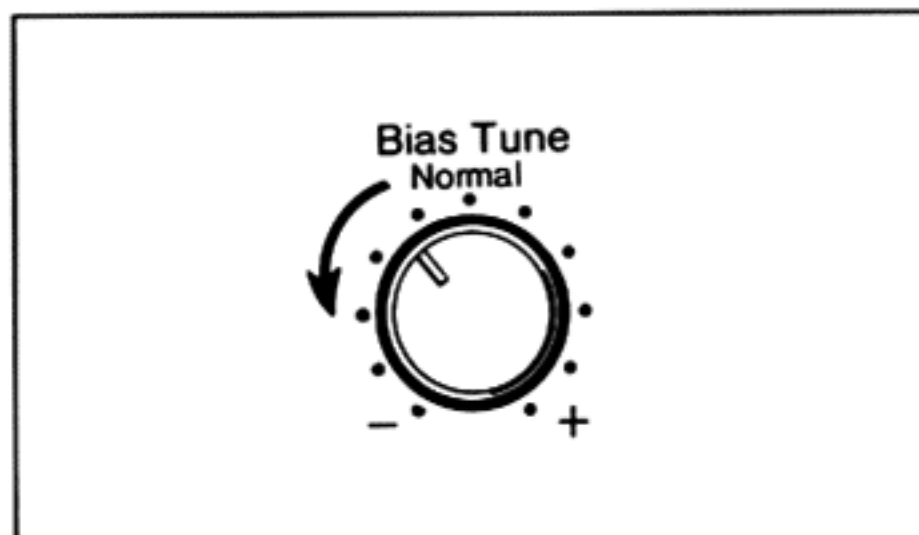

3. By repeatedly performing steps 1. and 2., if necessary, minimize the difference in sound quality between the source signal ("Source") and the recorded signal ("Tape").

When wishing to perform an absolutely accurate adjustment of bias, the prescribed procedure is as follows.

1. Set the Dolby NR switch to "Off".
2. Use a test tone oscillator, the Nakamichi T-100 Audio Analyzer, or a similar device.
3. Connect the oscillator output to the input terminals on the rear panel of the cassette deck.
4. Record test signals of 1 kHz and 15 kHz on the tape at a -20 dB level.
5. Adjust the bias tune control, while repeating the record/playback procedure if necessary, until both signals read -20 dB in playback.

### Note:

- This deck is factory-adjusted to give best results with Nakamichi EX II, SX and ZX cassette tapes.
- If tapes of inferior quality are used, the output in the high frequency range may not increase even if the bias current is lowered (the bias tune control is turned to the left); rather distortion only will increase.

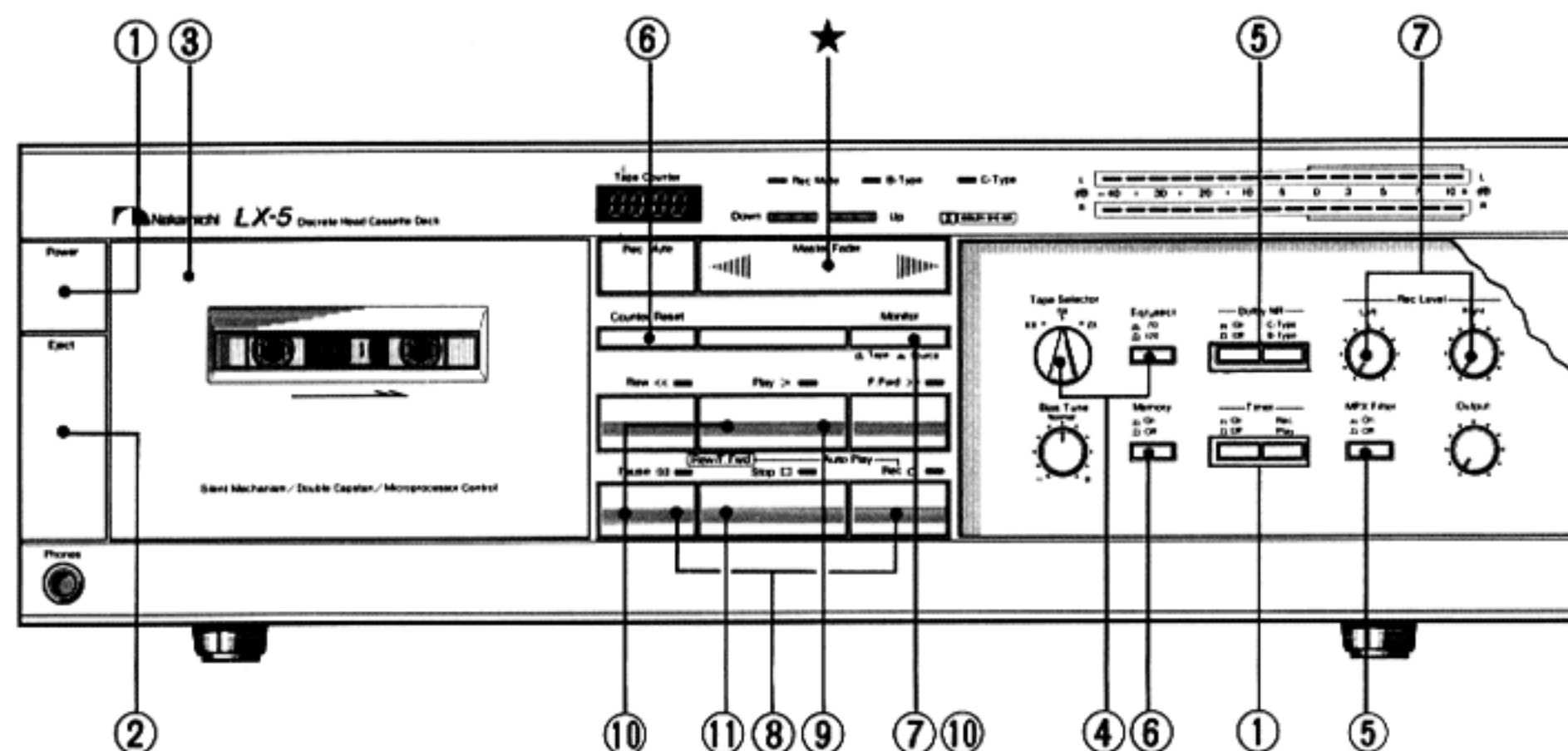

- ① Confirm that the On/Off button (left button) of the timer switch (16) is set to "Off". Turn on the power to the deck by depressing the power switch (1).
- ② Press the eject button (2) to open the cassette holder (4).
- ③ Insert the cassette tape into the holder with the exposed tape facing down. Push the cassette holder back until it locks into the panel.
- ④ Select the correct positions of the tape selector switch (11) and Eq switch (13) for the tape in use. (→p. 10)
- ⑤ If a Dolby NR system is to be used for recording, set the On/Off button (left button) of the Dolby NR switch (15) to "On" and select the desired system with the C-Type/B-Type button (right button). (The respective indicator of the Dolby NR indicators (22) lights up.) When the Dolby NR system is not to be used, set the On/Off button of the Dolby NR switch (15) to "Off".  
When recording from FM broadcasts, set the MPX filter switch (18) to "On".  
**Note:**  
— When recording from other program sources except FM broadcasts, the MPX filter switch should be set to "Off".
- ⑥ By pressing the counter reset button (28) to return the indication of the tape counter (26) to "0000" and setting the tape start memory switch (14) to "On", you can easily return to the starting point after recording is completed. The tape will stop automatically at the counter indication "0000" in rewind.
- ⑦ Set the monitor switch (21) to "Source" and, while watching the peak level meters (20), adjust the input level controls L,R (17) to obtain the correct recording level. (→p. 13)
- ⑧ While keeping the record button (10) depressed, press the pause button (6) to put the deck into the record-standby mode. The red indicator above the record button and the green indicator above the pause button light up.  
★ If you want to start the recording with a fade-in, press the "Down <" side of the master fader control (25) to return the fader to minimum. (→p. 7)
- ⑨ Press the play button (7) to start recording.  
★ To perform fade-in, now press the "Up >" side of the master fader control (25). The recording level is automatically brought up to the level determined in step ⑦.
- ⑩ To check the quality of the recording in progress, you can instantly monitor the playback signal by setting the monitor switch (21) to "Tape". In the "Source" position, the input signal before recording is heard.  
For short-term interruption of recording, press the pause button (6). To resume recording, press the play button (7) again.
- ⑪ By pressing the stop button (8), the recording mode is released and the tape transport comes to a full stop.  
★ If you want to end the recording with a fade-out, press the "Down <" side of the master fader control (25) to return the fader level to minimum and then press the stop button. After the stop button was pushed, the master fader control is automatically released and the level returns to the "Up >" value.

# Tips on Setting Record Levels

The LED level meters of this cassette deck are free of "overshoot" problems and display peak levels with a high degree of accuracy. For good recordings, it is essential to maintain a high signal-to-noise ratio. This is achieved by putting as much signal on the tape as is possible without producing distortion. Setting record levels too low will result in noisy recordings, while too high recording levels cause distortion. Finding the proper level between these two extremes is what good recording is all about. This task is facilitated by this deck's level meters which cover a wide 50 dB range and accurately display even very short signal peaks. Refer to the chart as a guideline to set recording levels.

**"Normal" (LH) position tape formulations,  
"Chrome" position tape formulations:**

The meters should be allowed to read as high as +5 dB on short program peaks.

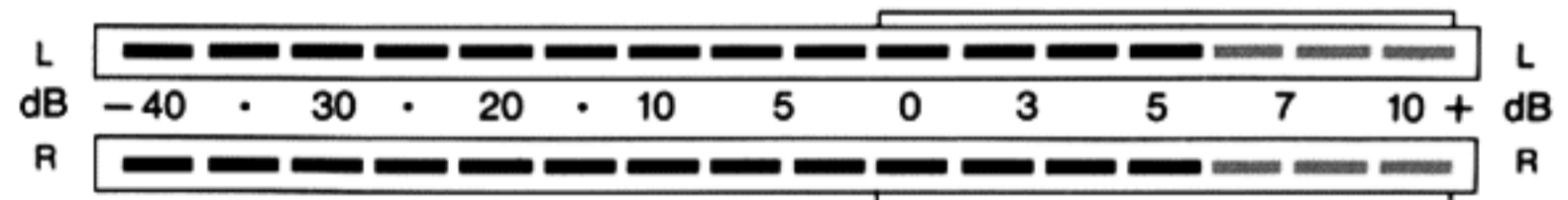

**"Metal" position tape formulations:**

The meters should be allowed to read as high as +8 dB on short program peaks.

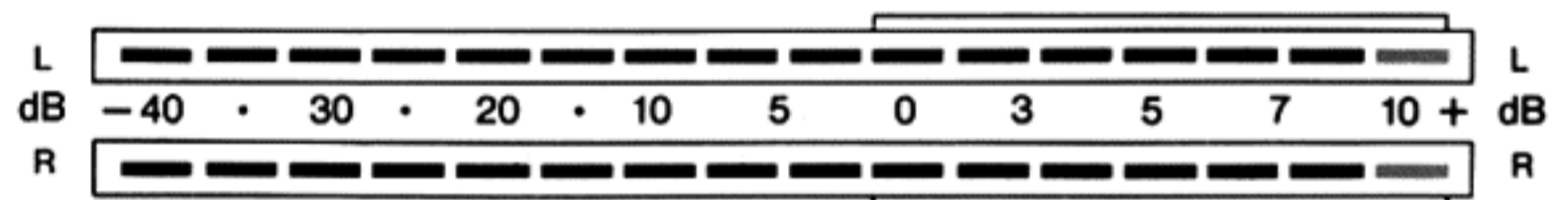

As different tape formulations have slightly different overload (headroom) characteristics, the requirements may vary to a certain degree when using different tapes.



# Dolby Noise Reduction System

This deck uses the Dolby noise reduction (NR) system, but with a difference: In addition to the Dolby B-Type noise reduction built into conventional cassette decks, it incorporates the newly developed Dolby C-Type noise reduction system.

Whereas the Dolby B-Type NR reduced noise in the high frequencies by about 10 dB, the Dolby C-Type NR with new characteristics achieves an improvement of about 20 dB in the range from 2 kHz to 8 kHz, where noise is most readily audible.

The operating principle of the Dolby C-Type NR is similar to the B-Type, in that it does not affect high-level signals in recording, but processes only low-level signals in the mid and higher frequency range. However, the operation of the C-Type system starts at a point 2 octaves lower than with the B-Type system, and it incorporates new circuits to prevent encode/decode errors or high frequency loss due to tape saturation. By using the Dolby C-Type NR, dynamic range is greatly enhanced and the setting of record levels becomes easy and trouble-free. This deck incorporates both the Dolby B-Type and the Dolby C-Type noise reduction systems. When playing back a tape from your collection which was recorded with the B-Type NR "on", the NR switch should be set to the "B-Type" position. When playing a tape recorded with the C-Type NR, the switch should be set to the "C-Type" position.

**Note:**

— This system does not reduce any noise already contained in the incoming input signal. You should therefore strive to use signals as noise-free as possible as a recording source.

To the ear, the Dolby C-Type NR system provides a constant noise reduction with any type of music, during signal as well as during silent passages. Modulation or breathing noise has been suppressed past audibility, and the tape's saturation level is increased by the action of the so-called "spectral skewing circuit" to determine pre-emphasis and de-emphasis, and the "Anti-Saturation Network (ASN)", etc.

Chart A illustrates the low-level encoding characteristics for the B-Type NR and the C-Type NR. Decoding is done with exactly opposite characteristics, thus achieving flat overall frequency response. As can be seen

from the chart, the operation threshold of the C-Type is two octaves lower than that of the B-Type, and in the high frequency range, noise reduction is by 20 dB.

Chart B shows an example of actual frequency response and noise spectrum analysis as recorded on a cassette deck. It is evident from the noise spectrum analysis that with the C-Type NR, noise is considerably lower than with the B-Type and that it is reduced by about 20 dB in the range from 2 kHz to 8 kHz. In addition, with the C-Type NR the ASN and skewing features etc. serve to increase high frequency MOL during high-level recording.

**Dolby NR Switch Operation**

When a Dolby noise reduction system is to be used, set the On/Off button (left button) of the Dolby NR switch (15) to "On" and select the desired system with the C-Type/B-Type button (right button).

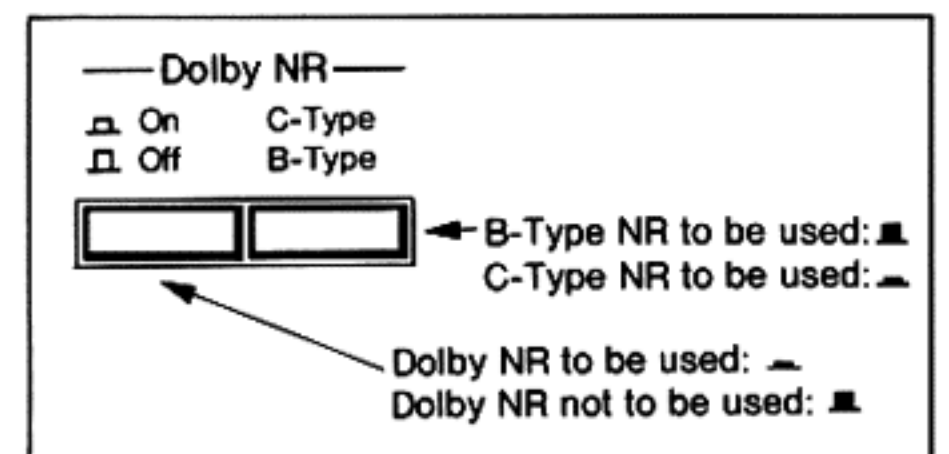

**Low-level Encoding Characteristics (-60 dB)**

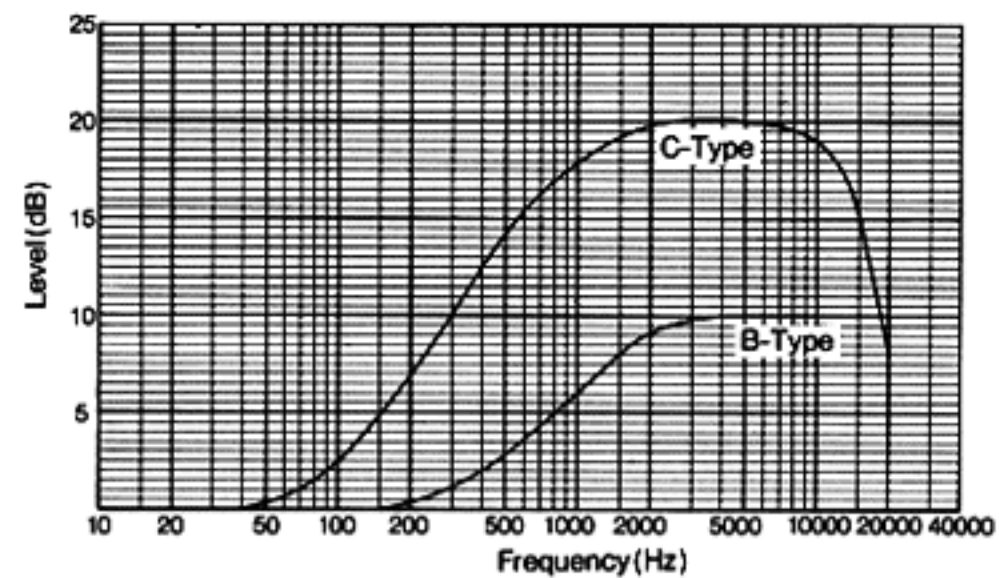

**Chart A**

**Frequency Response and Noise Spectrum Analysis**

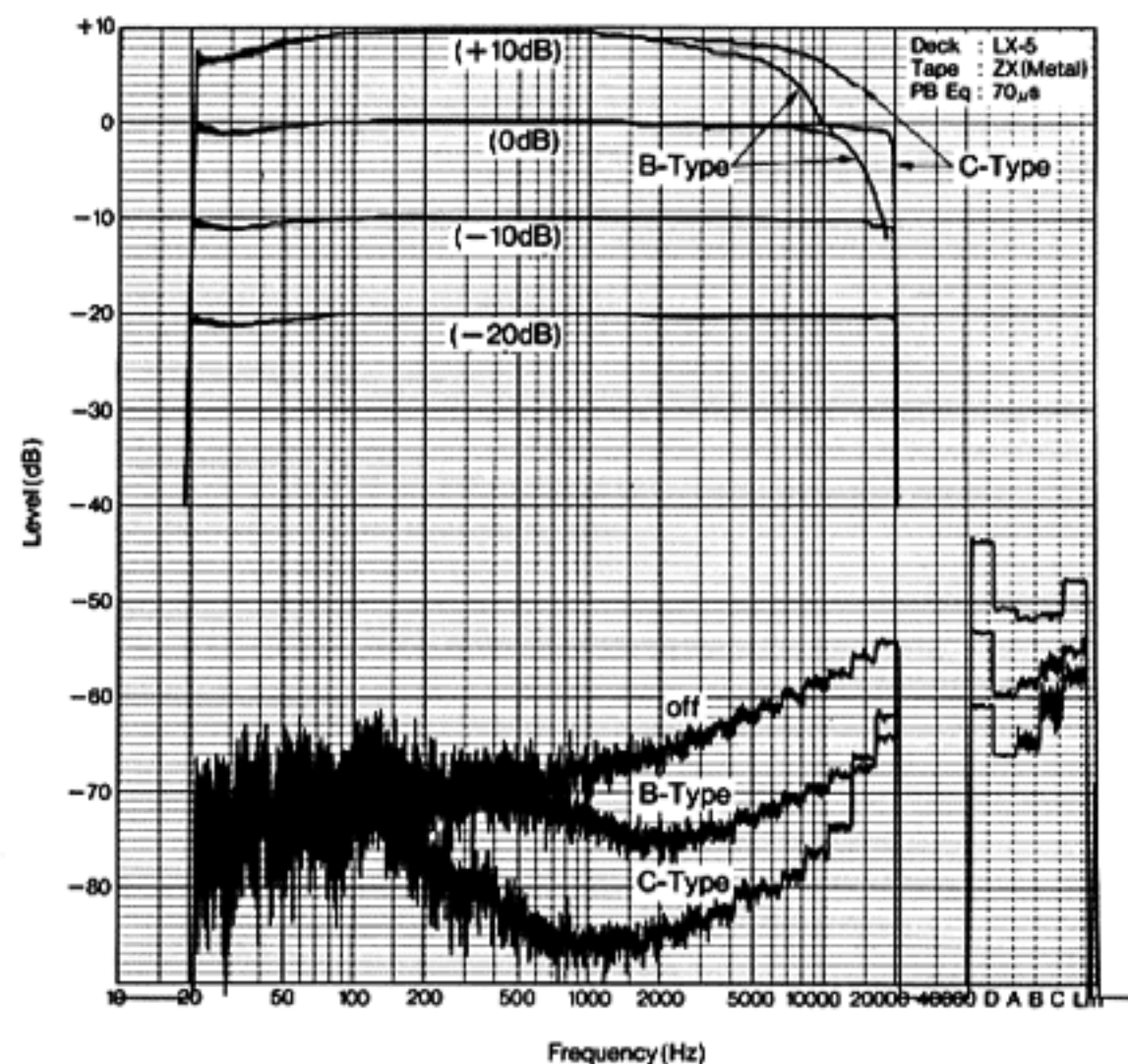

**Chart B**

# Maintenance

The cassette holder cover of this cassette deck can be easily removed. Perform cleaning or demagnetizing after removing the cover. In ordinary use, this cover should always be attached.

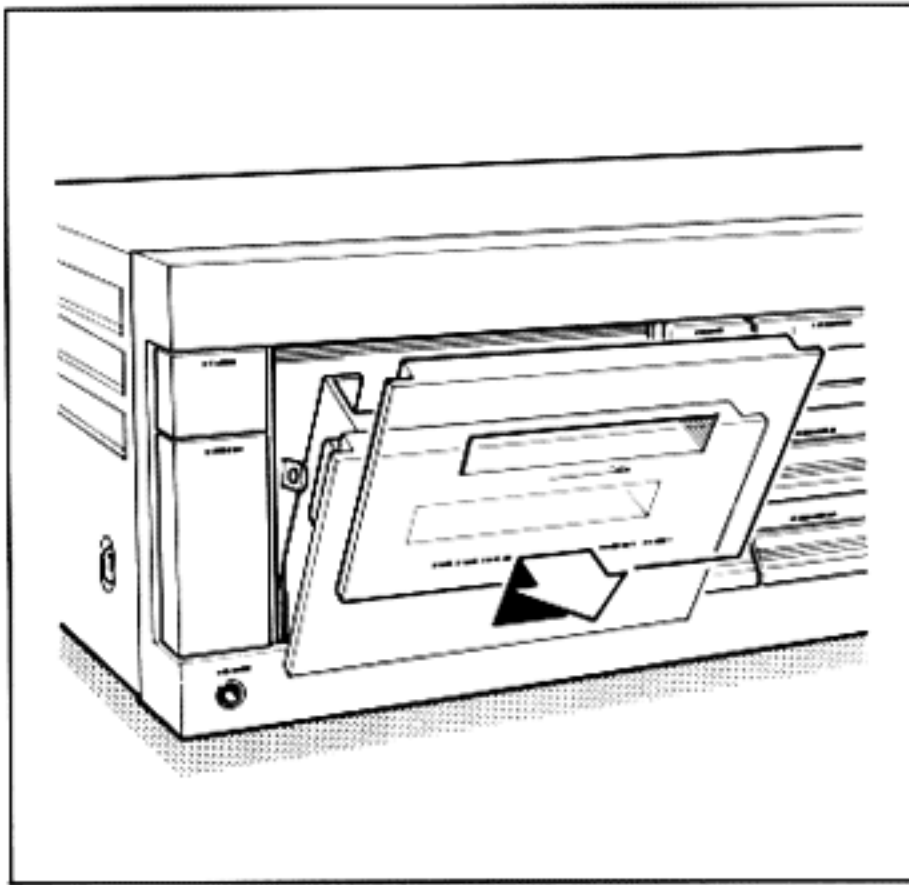

## Head and Transport Cleaning

It is very important to regularly clean the surfaces of the record head, playback head and erase head as well as the capstans, pinchrollers and all other parts which come in contact with the tape. Tiny particles shedded from the tape onto these parts, as well as dust accumulations etc. become the cause of drop-outs, and severely degrade frequency response and wow-and-flutter characteristics. Be sure to always keep the parts shown in white on the illustration spotlessly clean.

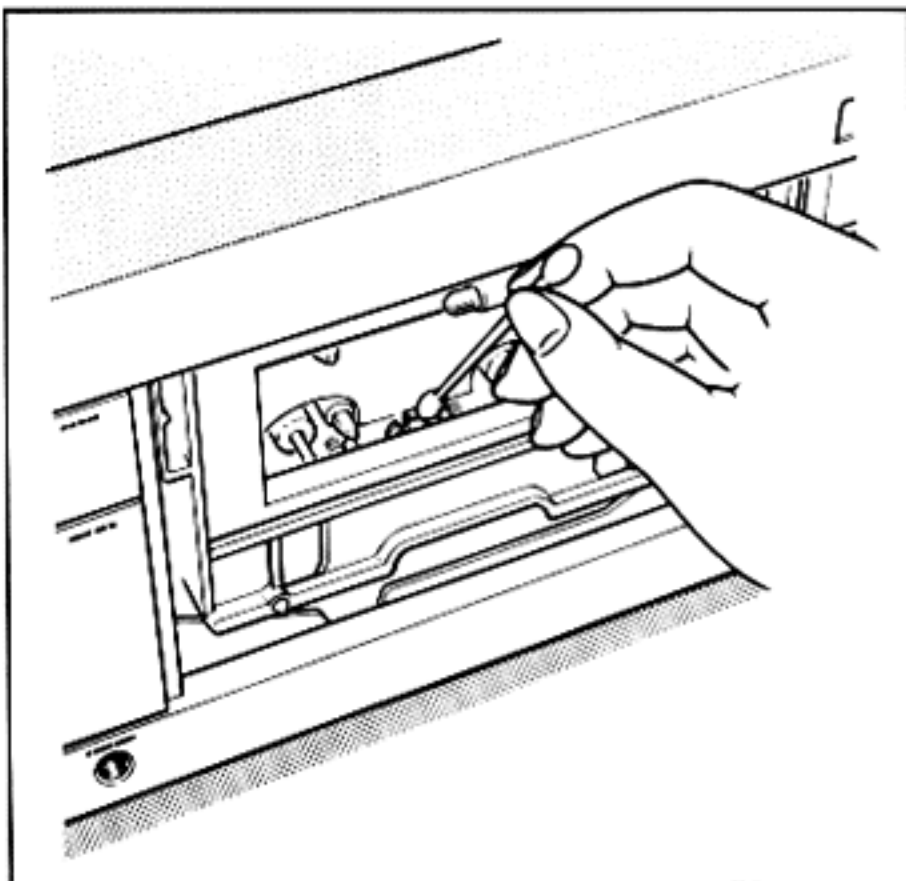

Cleaning should always be performed in the direction of the arrows in the chart (direction of tape travel).

## Cleaning Procedure:

1. Remove the cassette holder cover.
2. Use the enclosed cotton-tipped sticks and—with very light pressure—clean the parts indicated in white on the illustration. In case of severe contamination, dip the cotton tip in the enclosed alcohol before cleaning, or use the enclosed plastic stick with a sponge tip screwed onto its end and dipped in alcohol.

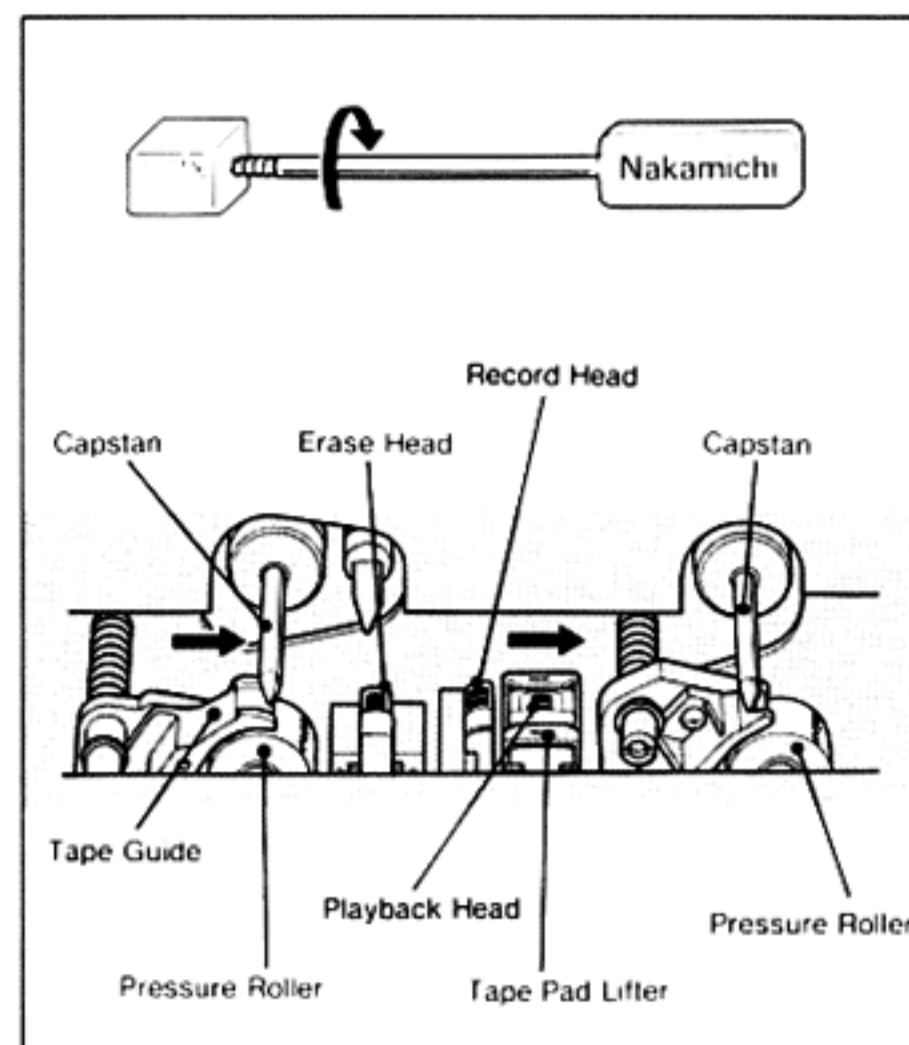

## Note:

- To easily reach the various parts for cleaning, turn on the power to the deck and put the deck into the play-standby mode (play button and pause button depressed). The head assembly is now raised.
- Be careful not to apply too much force in cleaning, as the respective parts are critically aligned.
- When you have used alcohol in cleaning, give the cleaned surfaces a minute or two to dry off completely before playing a tape.
- Be careful not to damage the tape guides or the tape pad lifter.
- When you have used cotton-tipped sticks, be sure to remove any cotton strands from the cleaned parts.

## Demagnetizing

After a longer period of use, there can be a build-up of residual magnetism in the playback head, record head and erase head. Such residual magnetism can induce noise and partially erase the high frequencies of a tape being played. To prevent this, you should demagnetize these parts about once every 50 hours of use with the Nakamichi DM-10 Demagnetizer (optional) or any other properly designed demagnetizer.

## Note:

- Always switch off the power to the deck before starting the demagnetizing procedure.

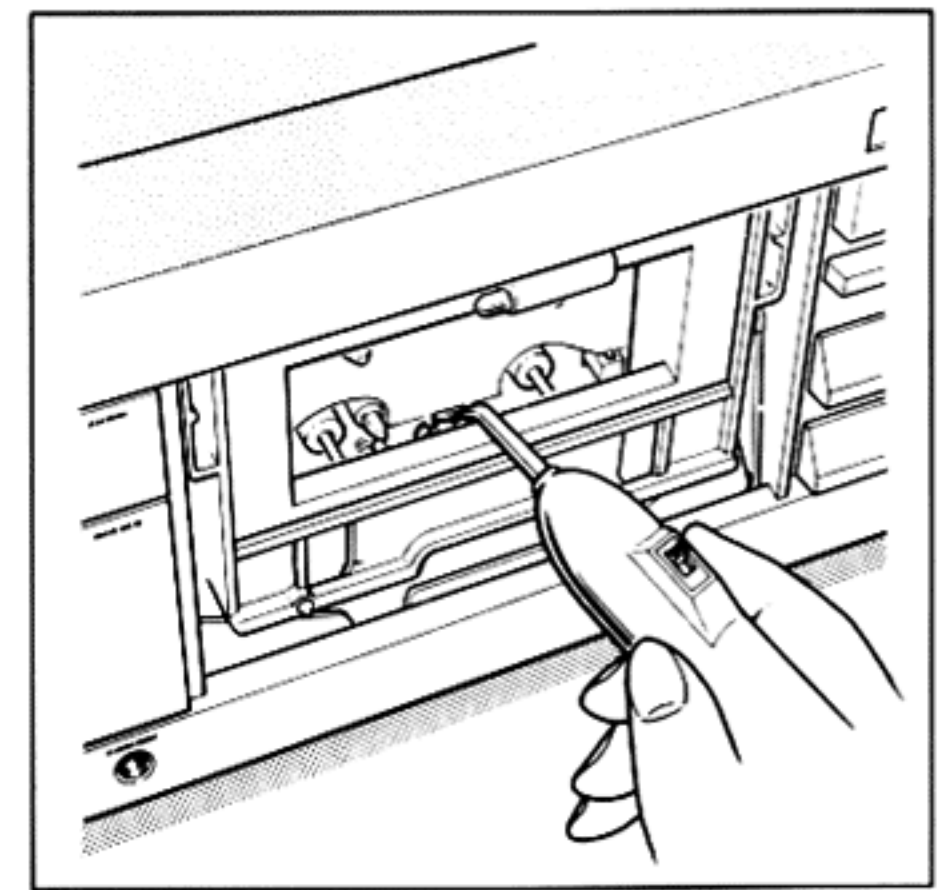

## Cleaning the Faceplate

Clean the faceplate only by wiping it with the enclosed polishing cloth or another soft cloth. Never use alcohol, solvents, ammonia or abrasive cleaning agents.

## Lubrication

All important moving parts of this deck are fitted with long-life, oil-less bearings. Periodic lubrication is therefore not necessary.

# Troubleshooting

Condition	Probable Cause	Remedy
Tape does not run.	<ol style="list-style-type: none"> <li>1. Power cord is unplugged.</li> <li>2. Cassette holder not completely locked.</li> </ol>	<p>Plug in cord firmly.</p> <p>Press eject button and then close cassette holder firmly.</p>
Record mode cannot be entered.	<ol style="list-style-type: none"> <li>1. No cassette inserted.</li> <li>2. Cassette tabs have been removed.</li> </ol>	Place adhesive tape over tab opening or use new cassette.
Excessive playback hiss.	Head is magnetized.	Demagnetize head.
Uneven sound levels, drop-outs, excessive wow/flutter	<ol style="list-style-type: none"> <li>1. Heads and/or capstans and pressure rollers dirty.</li> <li>2. Faulty cassette.</li> </ol>	<p>Clean these parts.</p> <p>Replace cassette.</p>
Incomplete erasure.	Erase head dirty.	Clean head and pressure roller.
Distorted record/playback sound.	<ol style="list-style-type: none"> <li>1. Program material itself is distorted.</li> <li>2. Recording levels are too high.</li> <li>3. Head dirty.</li> <li>4. Wrong setting of tape selector switch.</li> </ol>	<p>Check program material.</p> <p>Wide dynamic range permits some short-term overload, but excessive recording levels will cause distortion.</p> <p>Adjust recording levels.</p> <p>Clean head.</p> <p>Select correct setting for tape in use.</p>
Record mode is entered, but cannot record.	<ol style="list-style-type: none"> <li>1. Input disconnected.</li> <li>2. Head dirty.</li> <li>3. Master fader control is set to down.</li> </ol>	<p>Check connections.</p> <p>Clean head.</p> <p>Push the "Up" side of the master fader control.</p>
Cannot playback.	<ol style="list-style-type: none"> <li>1. Output disconnected.</li> <li>2. Head dirty.</li> <li>3. Monitor switch is set to "Source."</li> </ol>	<p>Check connections.</p> <p>Clean head.</p> <p>Set monitor switch to "Tape."</p>
Dull high frequencies.	<ol style="list-style-type: none"> <li>1. Heads dirty.</li> <li>2. Tape selector switch and/or equalizer switch not set correctly.</li> </ol>	<p>Clean heads.</p> <p>Select correct positions for tape in use.</p>
Hum heard during recording or playback.	<ol style="list-style-type: none"> <li>1. Strong induction fields near deck.</li> <li>2. Signal cable or connector grounding faulty.</li> </ol>	<p>Keep deck away from amplifier, transformers, fluorescent lamps, etc.</p> <p>Replace signal cables.</p>

# Specifications/Optional Accessories

## Specifications

Track Configuration.....	4 tracks/2-channels stereo
Heads.....	3 (erase head x 1, record head x 1, playback head x 1)
Motors (Tape Transport).....	DC servo motor (capstan drive) x 1 DC motor (reel drive) x 1
Power Source.....	100, 120, 120/220-240, 220 or 240V AC; 50/60Hz (According to country of sale)
Power Consumption.....	33 W max.
Tape Speed.....	1-7/8 ips. (4.8 cm/sec.) $\pm$ 0.5%
Wow-and-Flutter.....	Less than $\pm$ 0.11% Wtd peak Less than 0.06% Wtd rms
Frequency Response.....	20 Hz-20,000 Hz (recording level -20 dB, ZX, SX, EX II tape)
Signal-to-Noise Ratio.....	<b>Dolby C-Type NR on</b> <70 $\mu$ s, ZX tape> Better than 70 dB (400 Hz, 3% THD, IHF A-Wtd rms) <b>Dolby B-Type NR on</b> <70 $\mu$ s, ZX tape> Better than 64 dB (400 Hz, 3% THD, IHF A-Wtd rms)
Total Harmonic Distortion.....	Less than 0.9% (400 Hz, 0 dB, ZX tape) Less than 1.0% (400 Hz, 0 dB, SX, EX II tape)
Erase.....	Better than 60 dB (100 Hz, 0 dB)
Separation.....	Better than 36 dB (1 kHz, 0 dB)
Crosstalk.....	Better than 60 dB (1 kHz, 0 dB)
Bias Frequency.....	105 kHz
Input (Line).....	50 mV, 70 k $\Omega$
Output (Line).....	1V (400 Hz, 0 dB, output level control at max.), 2.2 k $\Omega$
(Headphones).....	12 mW (400 Hz, 0 dB, output level control at max.) 8 $\Omega$ load
Dimensions.....	450(W) x 135(H) x 307(D) millimeters 17-3/4(W) x 5-5/16(H) x 12-1/16(D) inches
Approximate Weight.....	8.5 kg 18 lb. 12 oz

- Specifications and appearance design are subject to change for further improvement without notice.
- Dolby NR under license from Dolby Laboratories Licensing Corporation.
- The word "DOLBY" and the Double-D-Symbol are trademarks of Dolby Laboratories Licensing Corporation.

SF-10 Subsonic Filter



## Optional Accessories

ZX Metalloy Cassette Tape  
C-60, C-90  
SX II Super Ferricobalt Cassette Tape  
C-60, C-90  
SX Ferricobalt Cassette Tape  
C-60, C-90  
EX II Ferricrystal Cassette Tape  
C-60, C-90  
EX Ferrioxide Cassette Tape  
C-60, C-90

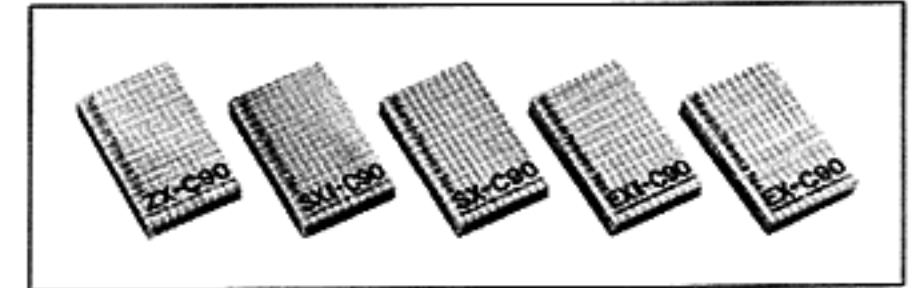

RM-200 Remote Control

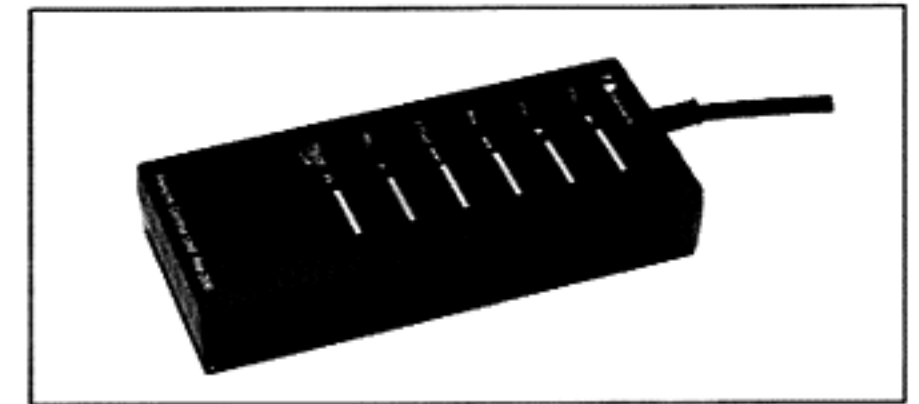

DM-10 Head Demagnetizer



SP-7 Stereo Headphones

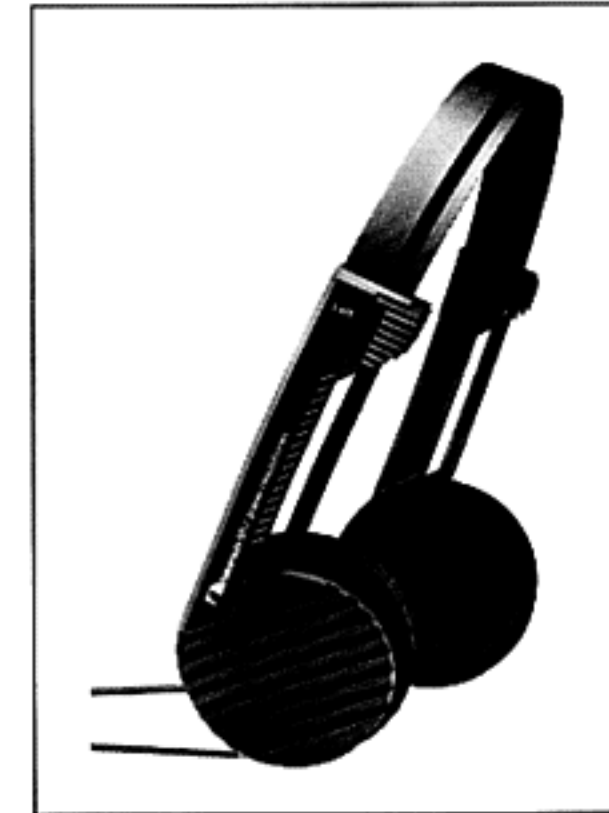

## Nakamichi Corporation

Tokyo Office  
Shinjuku Daiichi Seimei Bldg.  
2-7-1 Nishishinjuku, Shinjuku-ku, Tokyo  
Phone (03) 342-4461  
Telex : 2324721 (NAKAM J)

## Nakamichi U.S.A. Corporation

19701 South Vermont Avenue  
Torrance, California 90502  
Phone : (213) 538-8150

## Nakamichi GmbH

Stephanienstrasse 6, 4000 Düsseldorf 1  
Phone : (0211) 359036